

Pompe Oleopneumatiche Aria/Olio

Pressioni di esercizio da 192 a 320 bar

Air/Oil hydraulic pumps

Working pressures from 192 to 320 bar



Disponibili in 3 rapporti
Mandata in doppio effetto

3 ratios available
dual action delivery

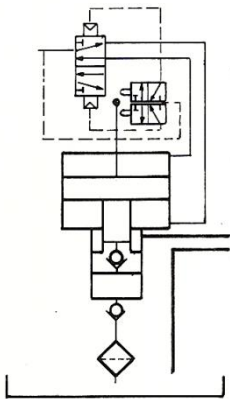

CARATTERISTICHE GENERALI e APPLICAZIONI

- Alternativa a moltiplicatori di pressione o centraline oleodinamiche.
- Funzionamento con normale linea d'aria da 3 a 8 bar
- Regolazione dell'aria in entrata consente di ottenere portate e pressioni variabili.
- Stop automatico a raggiungimento di equilibrio della pressione.
- Restart automatico per compensare il calo di pressione dovuto alla diminuzione di volume dell'olio.
- Pressione aria max 8 bar
- Mantenimento della pressione a tempo indeterminato senza consumo di energia.
- Ideali per l'alimentazione di circuiti ad alta pressione e per il comando di: cilindri a semplice e doppio effetto, a corsa breve, moduli o attrezzature con cilindri multipli a semplice effetto o piccole pressette per piegare, marcare, forare, laminare, tranciare, punzonare e ricalcare.

GENERAL CHARACTERISTICS and APPLICATIONS

- Alternative to pressure multipliers or hydraulic unit.
- Functioning with normal air line from 3 to 8 bars
- Regulation of inlet air allows obtaining variable capacities and pressures.
- Stop automatic after attainment of pressure equilibrium.
- Automatic restart in order to compensate the pressure drop due to the oil volume decrease.
- Air pressure max 8 bar
- Maintenance of pressure for infinite time without power consumption.
- Ideals for the feeding of high pressure circuits and for the control of: simple and double effect cylinders, short stroke cylinders, modules or equipments with multiple cylinders simple effect, or small presses for folding, marking, piercing, to rolling, blanking, punching and upsetting.

CHIAVE DI CODIFICA • KEY TO CODE

TIPO POMPA PUMP TYPE	MODELLO MODEL	RAPP. DI PRESSIONE PRESSURE RATIO	EROGAZ. OLIO OIL FLOW CM3	VERSIONE VERSION	CAPAC. SERBATOIO TANK CAPACITY LT	SPECIFICHE TECNICHE SPECIFICATIONS	N° MODULI BLOCKS N°		
PMPO	160	24	36	D	0 = SENZA SERBATOIO NO TANK	S = VALV. COMANDO SEMPLICE EFFETTO, SCARICO OLIO PILOT. PNEUMATICO SINGLE ACTING VALVE, OIL DISCHARGE BY PNEUMATIC PILOTAGE	- = 1 MODULO 1 BLOCK		
		40	22		3 = 3 lt			SE = VALV. COMANDO SEMPLICE EFFETTO, SCARICO OLIO PILOT. PNEUMATICO, VALVOLA PNEUMATICA E FILTRO REGOL. SINGLE ACTING VALVE, OIL DISCHARGE BY PNEUMATIC PILOTAGE, PNEUMATIC VALVE AND REGULATOR FILTER	2 = 2 MODULI 2 BLOCKS
		52	17		6 = 6 lt 10 = 10 lt 16 = 16 lt 25 = 25 lt				
						D = PREDISP. PER MONTAGGIO ELETTROVALVOLA OLEODINAMICA PREDISPOSITION FOR INSTALLATION HYDRAULIC VALVE			
						DE = PRED. PER MONT. ELETTROVALVOLA OLEODINAMICA + VAL. COMAND. PNEUM. E FILTRO REGOLAZIONE PREDISPOSITION FOR INSTALLATION HYDRAULIC VALVE+ PNEUMATIC VALVE AND REGULATOR FILTER			
						E = FILTRO REGOLATORE E VALV. PNEUMATICA REGULATOR FILTER AND PNEUMATIC VALVE			
						PE = PILOTAGGIO ESTERNO OUTER PILOTAGE			



AVVERTENZE

- Per il buon funzionamento si consiglia di utilizzare aria filtrata e non lubrificata, montando un gruppo (filtro+ regolatore) con portata minima NL/min. 400.
- Per impieghi con pressione < 3 bar è necessario richiedere versione con pilotaggio esterno, in questo caso collegare al foro (B) aria di linea superiore a 4 bar.
- Per impieghi con cilindri a doppio effetto la pompa deve essere equipaggiata di distributore idraulico per la gestione dell'olio.
- PORTATA: variabile, a vuoto 2÷3 l/min., decrescendo fino a portata zero raggiungendo l'equilibrio.

WARNINGS

- To ensure a good functioning to work with filtered and not lubricated air is recommended, by mounting a (filter+regulator) group with minimum capacity 400 NL/min.
- For applications with pressure < 3 bar is necessary to ask for the version with external pilotage, in this case attach to the hole (B) airline greater than 4 bars.
- For applications with dual action cylinders, the pump must be equipped with hydraulic distributor for the oil control.
- CAPACITY: variable, 2÷3 l/min. in empty condition, decreasing till capacity zero catching up the equilibrium.

Pompe Oleopneumatiche Aria/Olio

Pressioni di esercizio da 192 a 320 bar

Air/Oil hydraulic pumps

Working pressures from 192 to 320 bar



VERSIONE **BASE** BASE VERSION

CODIFICA CODE
PMPO D.3

CARATTERISTICHE

- Serbatoio standard capacità 3 litri
- Serbatoio maggiorato a richiesta
- Montare distributore idraulico per la gestione dell'olio per utilizzi con cilindri a semplice e doppio effetto.
- Per utilizzi con pressione aria sotto 3 bar collegare al foro ② aria di linea superiore a 4 bar.

CHARACTERISTICS

- 3 liters standard tank capacity.
- Bigger tank under demand.
- An automatic distributor for oil control it's necessary for applications with single and dual action cylinders.
- For use with air under pressure 3 bars attach to the hole ② airline greater than 4 bars

① = Aliment. max. 8 bar min. 3 bar - 1/4 Gas
Feed max 8 bar min. 3 bar - 1/4 Gas

② = Entrata aria pilotaggio esterno - 1/4 Gas
Inlet air for external pilotage - 1/4 Gas

Ⓜ = Scarico olio - 3/8 GaS
Oil discharge - 3/8 Gas

Ⓨ = Uscita olio - 3/8 Gas
Oil outlet - 3/8 Gas

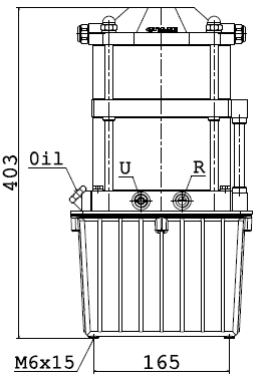
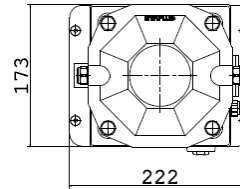
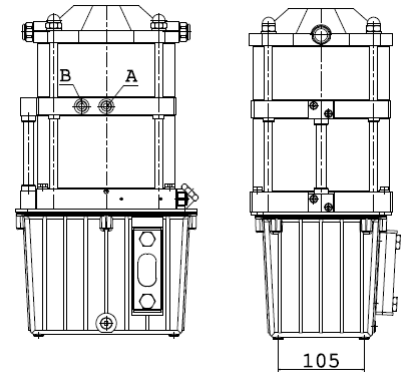
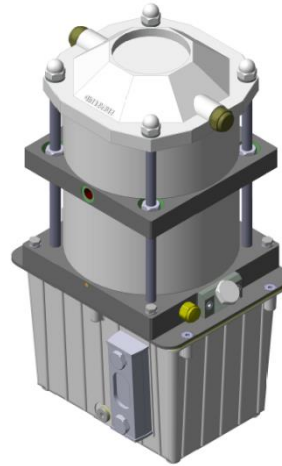

VERSIONE **"S"** PER CIRCUITI A SEMPLICE EFFETTO "S" VERSION FOR SINGLE ACTION CIRCUITS



CODIFICA CODE
PMPO D.3.S

CARATTERISTICHE

- Come versione base, fornita di valvola per comando di cilindri a semplice effetto con pilotaggio pneumatico per la messa a scarico dell'olio.

CHARACTERISTICS

- As per base version, equipped also with single action valve and oil discharge with pneumatic pilotage.

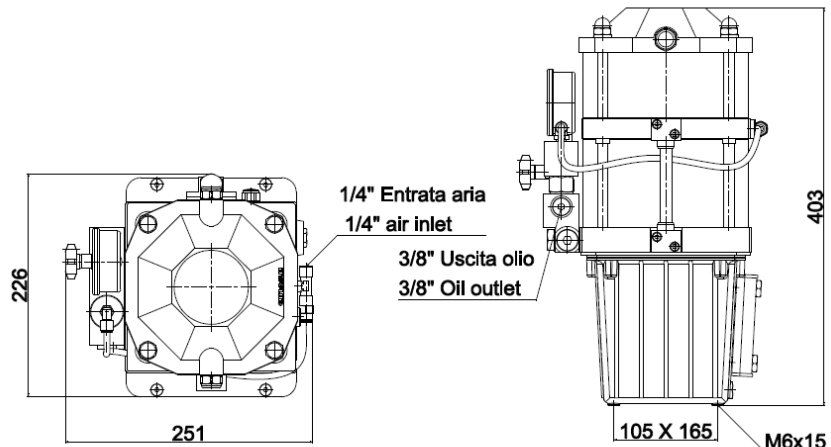

Pompe Oleopneumatiche Aria/Olio

Pressioni di esercizio da 192 a 320 bar

Air/Oil hydraulic pumps

Working pressures from 192 to 320 bar



VERSIONE "SE" PER CIRCUITI A SEMPLICE EFFETTO "SE" VERSION FOR SINGLE ACTION CIRCUITS

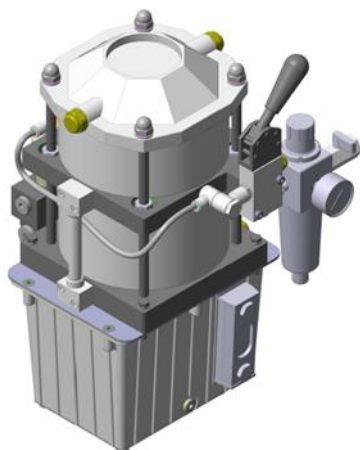

CODIFICA CODE
PMPO D.3.SE

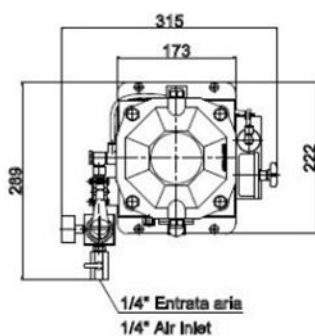
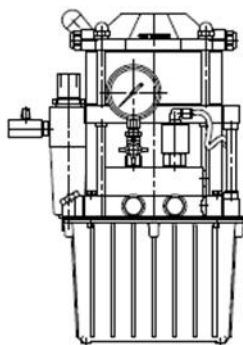

CARATTERISTICHE

- Come versione precedente equipaggiata inoltre di gruppo filtro-regolatore-valvola di comando entrata aria

CHARACTERISTICS

- As per "S" version equipped also with filter+regulator +control valve for inlet air group.

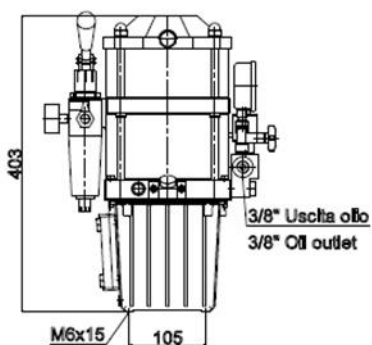
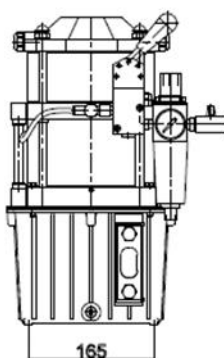

VERSIONE "D" PER CIRCUITI A DOPPIO EFFETTO CON POSS. DI UTILIZZO MODULI CETOP IN PARALLELO PER LA GESTIONE DI PIU' CIRCUITI

"D" VERSION FOR DOUBLE ACTION CIRCUITS WITH BLOCKS CETOP IN PARALLEL FOR THE GESTION OF MORE CIRCUITS

CODIFICA CODE
PMPO D.3.D

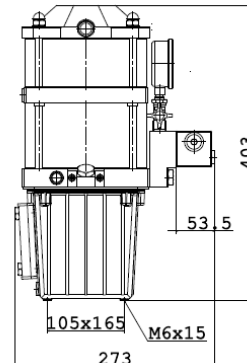

DIAGRAMMA DIAGRAM

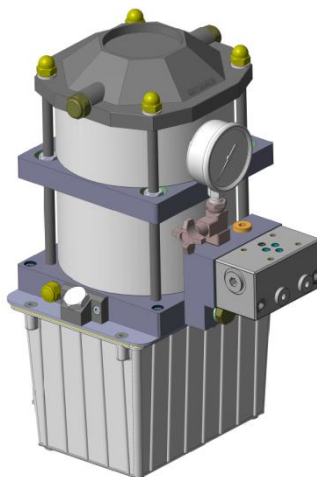
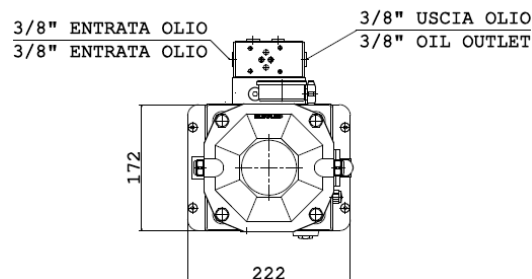
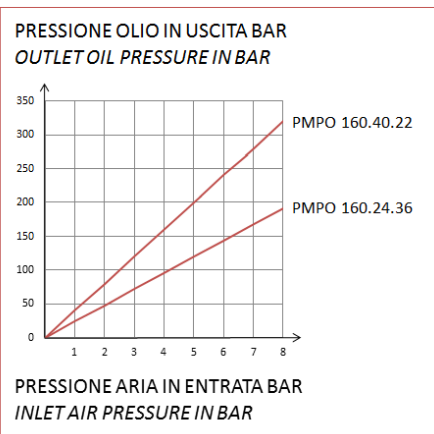

DATI TECNICI E DIMENSIONI • SPECIFICATIONS AND DIMENSIONS

MODELLO MODEL	Rapporto di pressione Pressure ratio	Erogazione olio per corsa cm ³ Oil flow per stroke cm ³	Erogazione olio a 6 bar NL/min. Oil flow at 6 bar NL/min.	Pressione olio con aria a Oil pressure with air at	
				8 bar	6 bar
PMPO 160.24.36	1:24	24	3	192	144
PMPO 160.40.22	1:40	15	2	320	240
PMPO 160.52.17	1:52	11	1,5	416	312